

Abas barko & Stora

18456

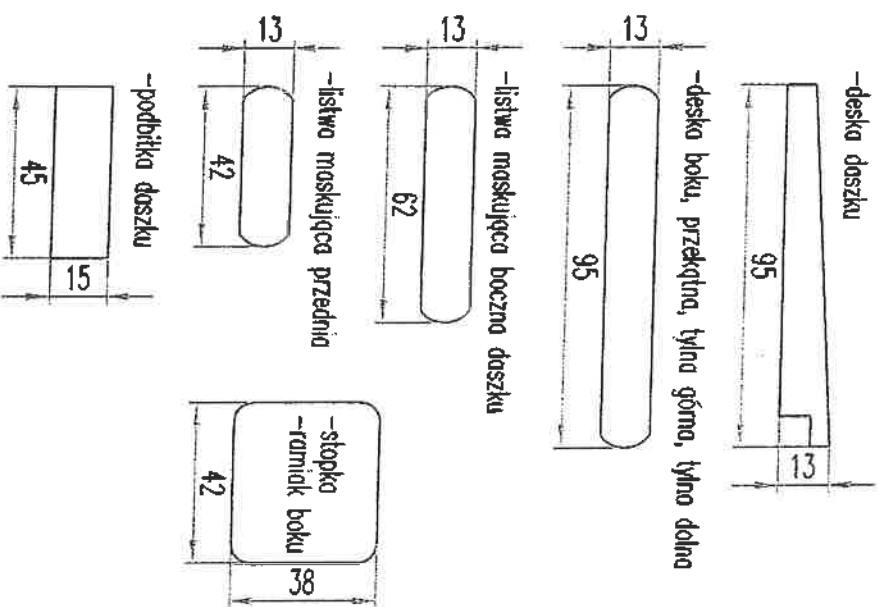
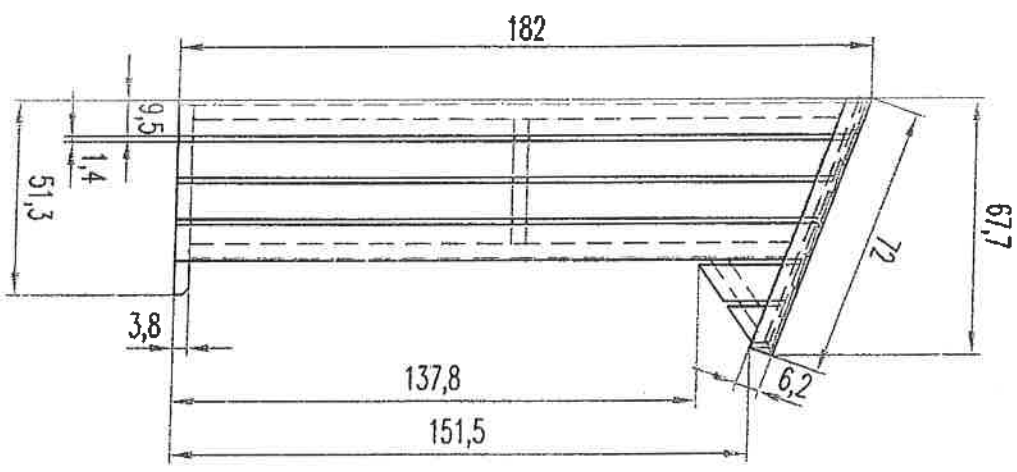
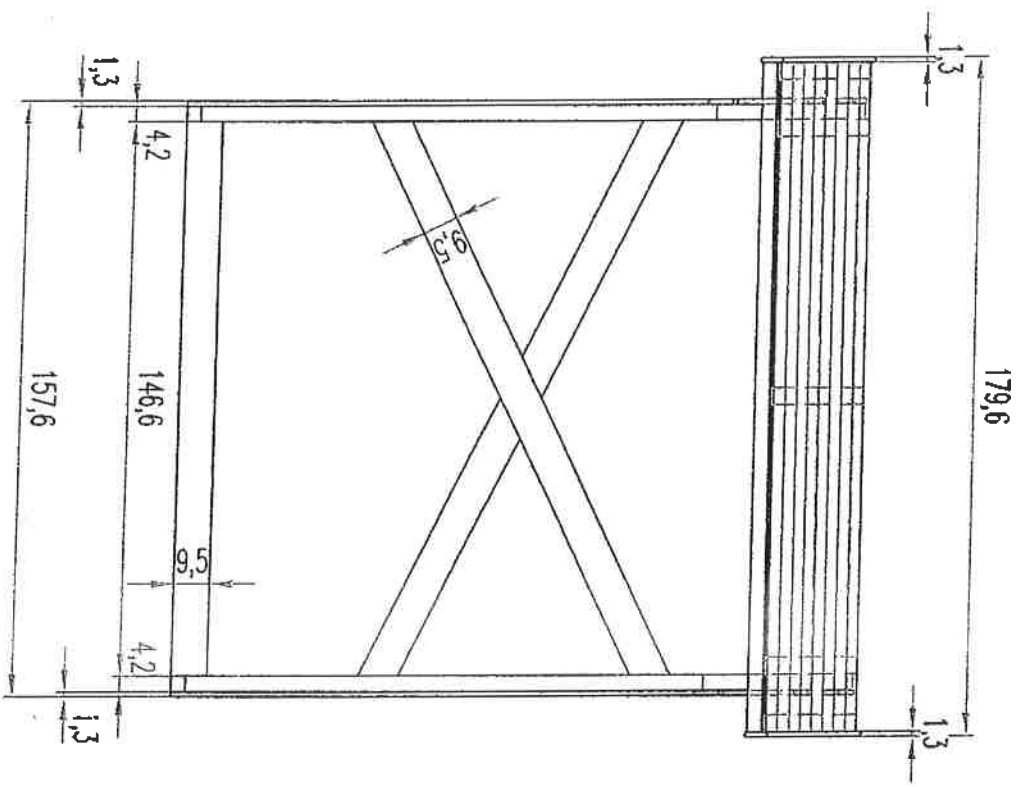

P.0041

Nr rysunku

Nr ark. Nazwa wyrobu

Drewnitnia 180x180x68  
(PLP 001140); (GD 991040)

Podziałka 1:20  
Data wykonania 31.05.2012  
Wykonani J. Chwińkiewicz

Uwagi

Polpro Sp. z o.o.  
Milič

# Abr. bølge & staves Ref M8456

1/2

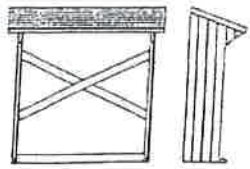

PLP 001140

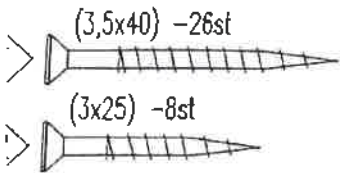
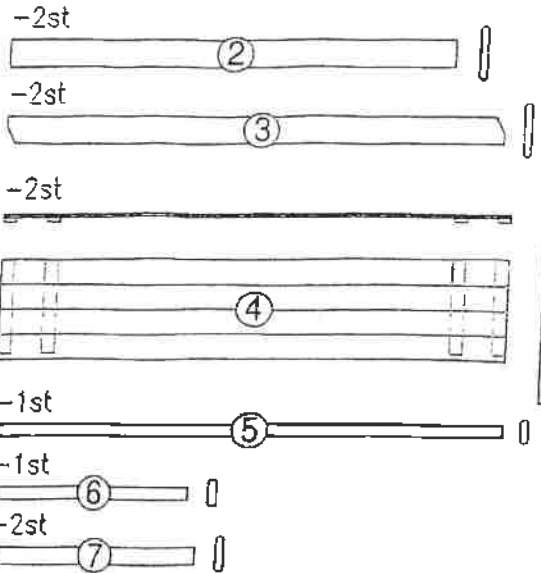
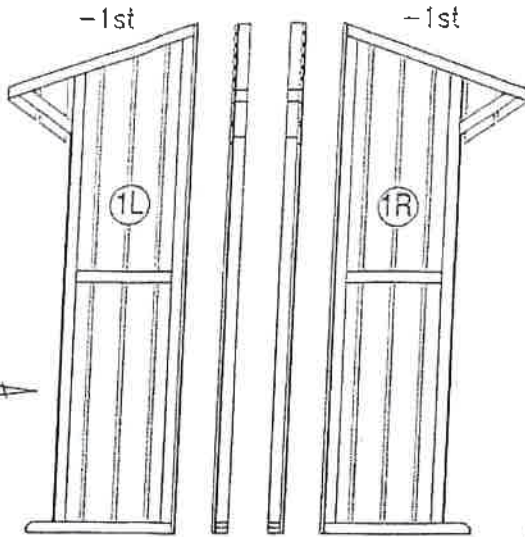

01

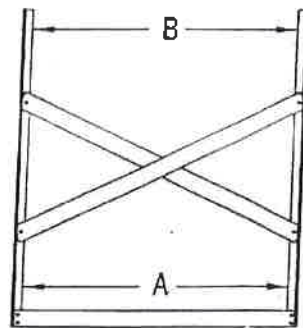
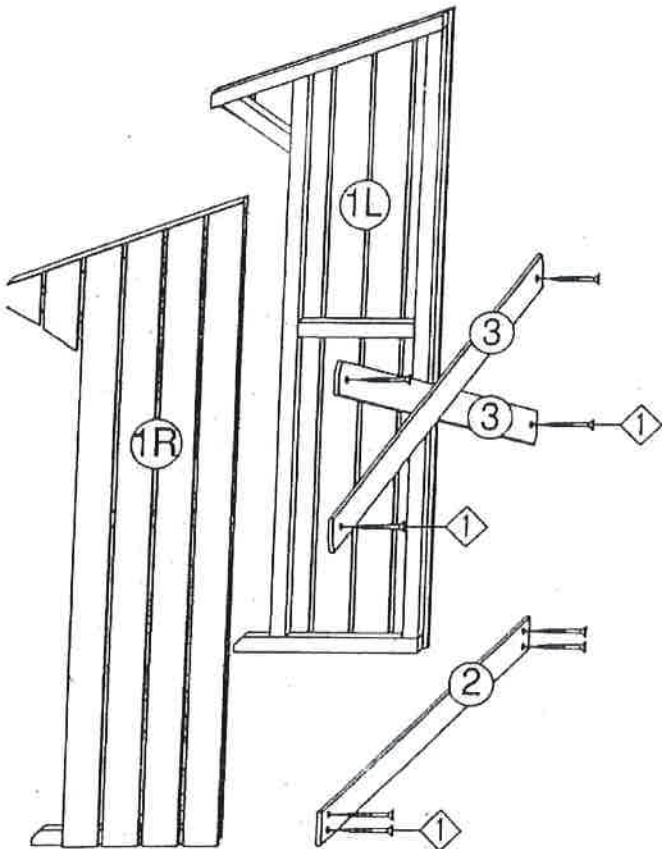

02

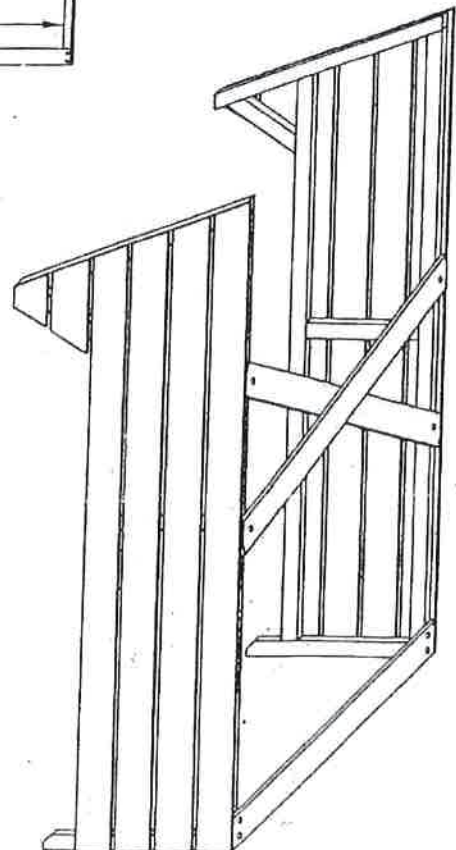

- (S) Vi rekommenderar förborming av skruvhålen!
- (NL) Voor alle schroeven adviseren wij de gaten voor te boren!
- (D) Vor dem Schraubeneindrehen soll man die Löcher boren!
- (UK) For all screws we advise to pre-bore the holes!
- (F) Pour toutes les vis nous vous recommandons de percer des trous!

03

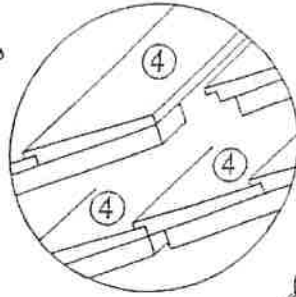
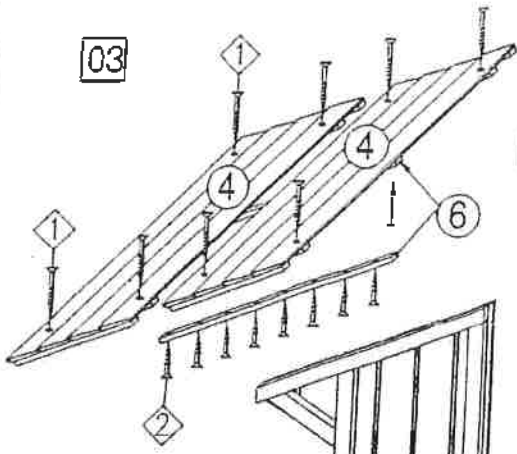

04

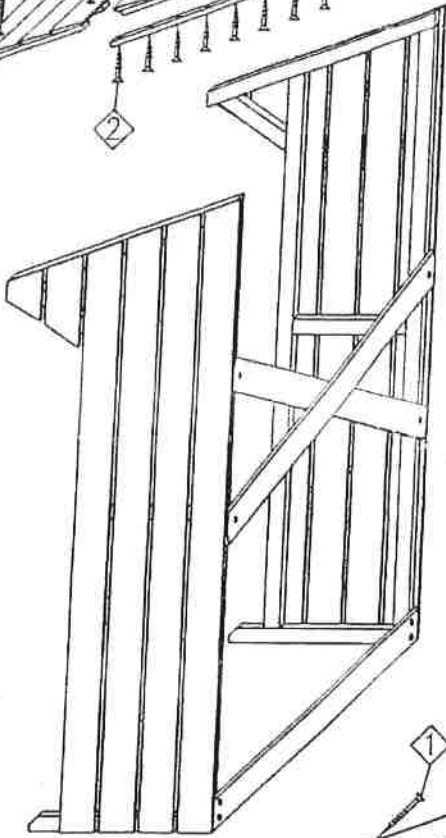
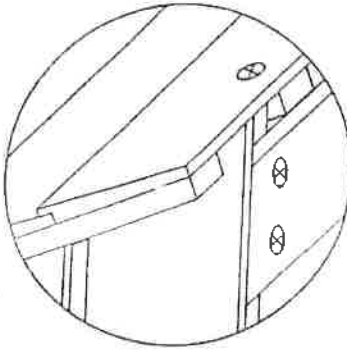
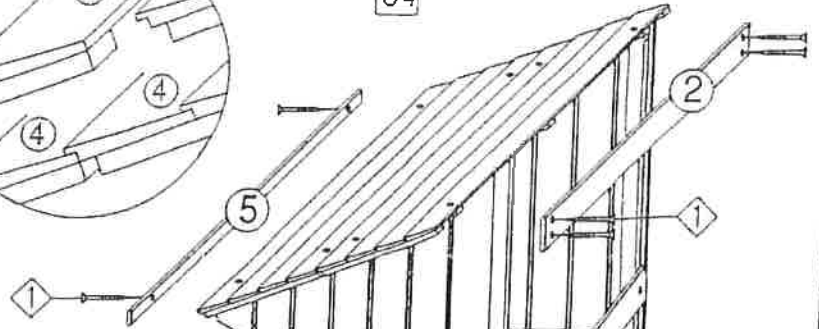

06

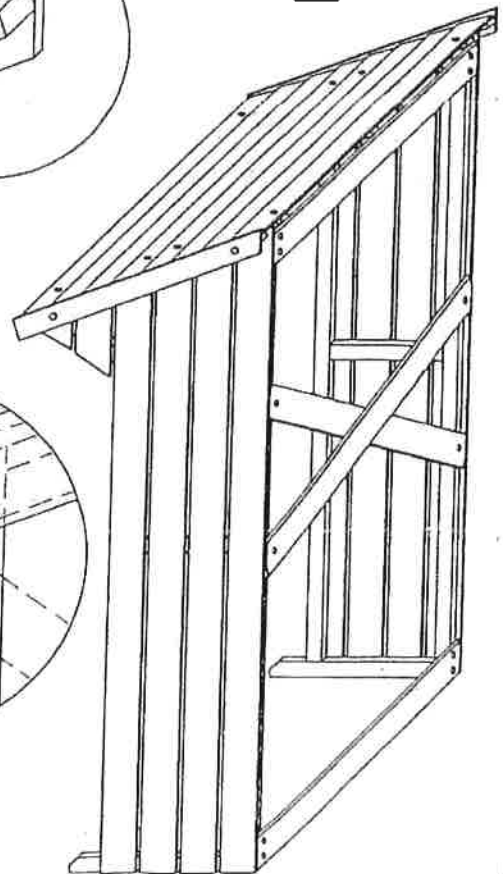

05

