

# PEUGEOT



## EnergySaw-305STB2



132055-A-20180501 - PEUGEOT OUTILLAGE

**FR** MANUEL D' UTILISATION (Notice originale):  
**NL** HANDBOEK (Vertaling van het oorspronkelijke):  
**ES** MANUAL (Traducción del original):  
**PT** MANUAL (Tradução do manual original):  
**IT** MANUAL (Traduzione dell, avvertenza originale):  
**EN** USING MANUAL (Original manual translation):

*Scie à onglets radiale*  
*Radiaal verstekzaag*  
*Sierra ingletadora radial*  
*Serra a onglete radial*  
*Troncatrice radiale*  
*Sliding electric mitre saw*

[peugeot-1810.com](http://peugeot-1810.com)

**FR**

Une scie à onglet sert à réaliser simultanément ou non des coupes en angle et en biseau de manière précise sans risque de déviation de la lame - très utile pour les travaux d'encadrement, de décoration tels que pose de lambris et parquet.

Plus le nombre de dents est important, plus la coupe est fine.

La fonction radiale, si votre machine en est équipée, permet de couper des pièces plus larges par exemple lames de parquet, planches de coffrage, étagères...

Le laser, si votre machine en est équipée, permet de projeter un faisceau matérialisant le passage de l'outil.

Recherchez une machine dont les capacités de coupe conviennent aux travaux que vous souhaitez entreprendre.

**EN**

A mitre saw is used to make precise simultaneous angled and bevelled cuts, without any risk of the blade slipping - very useful for making picture frames and for decorative work such as wood panelling or flooring.

The more teeth the blade has, the finer the cut.

The radial function, if your machine has it, means that you can cut wider pieces, for example: parquet strips, shuttering boards, shelves, etc.

The laser, if your machine has one, produces a beam of light which shows you where the blade will go.

Look for a machine whose cutting capacities are suited to the kind of work you are doing.

**ES**

Una sierra de ingletes sirve para realizar simultáneamente o no cortes en ángulo y en bisel de forma precisa sin riesgo de desviación de la hoja - muy útil para la realización de marcos, los trabajos de decoración tales como la colocación de frisos y parquet.

Cuanto más importante es el número de dientes, más fino es el corte.

La función radial, si su máquina está equipada con esta función, permite cortar piezas más anchas, como por ejemplo: tablas de parquet, tablas para encofrados, estantes...

El láser, si su máquina está equipada con esta función, permite proyectar un haz que materializa el paso de la herramienta.

Busque una máquina cuyas capacidades de corte sean convenientes para las obras que desea realizar.

**IT**

Una sega per tagli obliqui serve a realizzare simultaneamente o no dei tagli ad angolo e obliqui in modo preciso, senza rischio di deviazione della lama - molto utile per i lavori di incorniciatura, di decorazione come la posa di rivestimenti in legno e parquet.

Più il numero di denti è importante, più il taglio è perfetto.

La funzione radiale, se la vostra macchina ne ha una, permette di tagliare dei pezzi più larghi, per esempio: lame di parquet, tavole per armatura, mensole...

Il laser, se la vostra macchina ne ha uno, permette di proiettare un fascio che materializza il passaggio dell'attrezzo.

Cercare una macchina la cui capacità di taglio è adeguata ai lavori che si vogliono fare.

**PT**

Uma serra angular permite realizar, simultaneamente ou não, cortes em ângulo e em bisel de maneira precisa e sem riscos de desvio da lâmina - muito útil para a confecção de molduras e trabalhos de decoração, como a colocação de lambris e parquets.

Quanto maior é o número de dentes, mais fino é o corte.

A função radial, se a sua máquina possuir este recurso, permite cortar peças mais largas. Ex.: lâminas de parquet, placas de cofragem, prateleiras, etc.

O laser, se a sua máquina possuir, permite projectar um feixe que materializa a trajectória da ferramenta.

Opte por uma máquina cujas capacidades de corte convenham ao trabalho que deseja realizar.

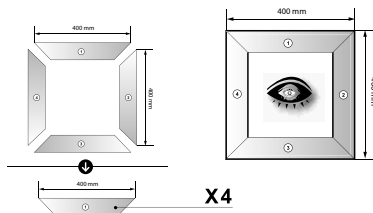



**FIG. A & B**

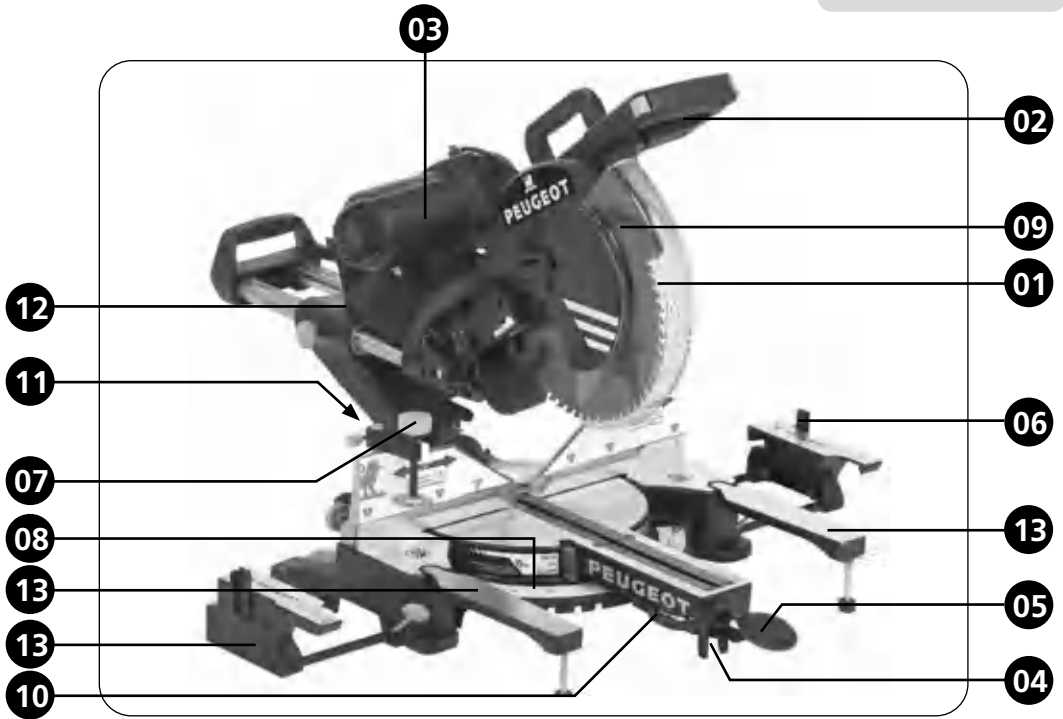



**FIG. C**

Contenu du carton  
Inhoud van de doos  
Conteúdo da caixa  
Contenido de la caja  
Contenuto della confezione  
Contents of the box

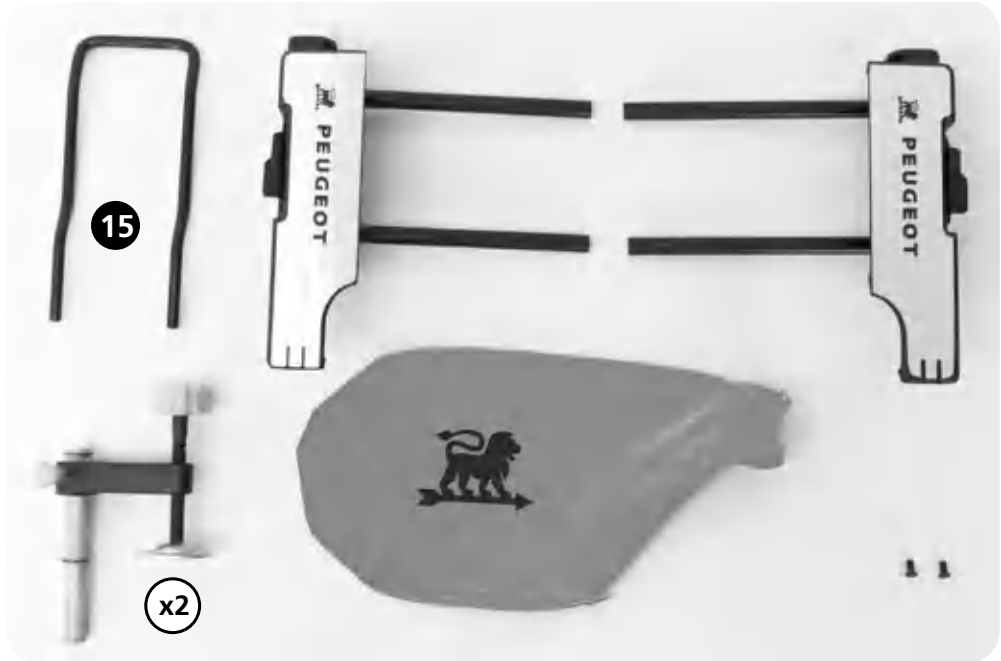

3  
x2



x2





**FIG. D**

01

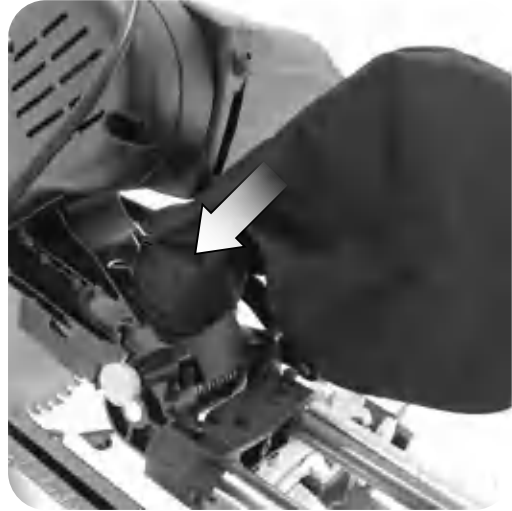
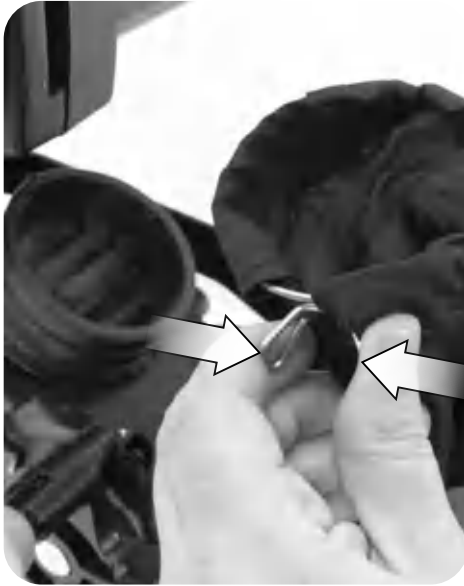

02

**Montage des extensions de table**

Montage van de tafel extensies  
El montaje de las extensiones de la mesa  
Montar as extensões de mesa  
Montaggio delle prolunghe  
Mounting the table extensions

**Répéter l'opération pour l'autre côté**

Herhaal dit voor de andere kant  
Repita para el otro lado  
Repita a operação para o outro lado  
Ripetere l'operazione per l'altro lato  
Repeat operation for the other side

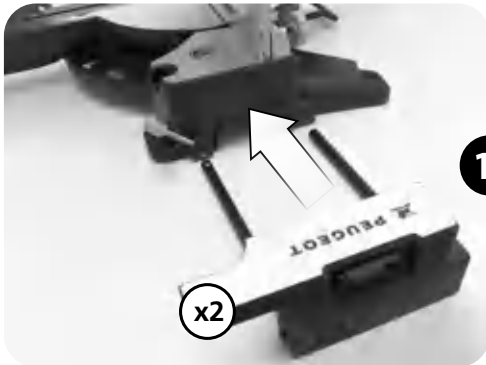

13



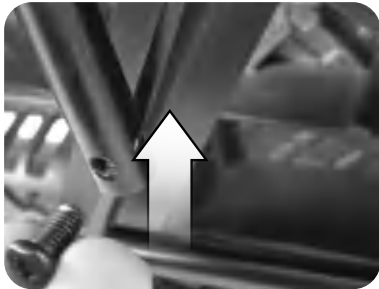

**FIG. D**

**02**

**Vis de verrouillage des extensions**

Borgschroef extensies  
Bloqueo de extensiones de tornillo  
Bloqueo extensões de parafuso  
Blocco estensioni a vite  
Extensions blocking screw



**Répéter l'opération pour l'autre côté**

Herhaal dit voor de andere kant  
Repita para el otro lado  
Repita a operação para o outro lado  
Ripetere l'operazione per l'altro lato  
Repeat operation for the other side

**02**

**Sécurité anti-basculement**

Anti-kantelmechanisme  
Antivuelco  
Mecanismo anti-tombamento  
Meccanismo anti-ribaltamento  
Anti-tipping mechanism

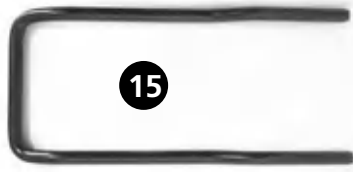

**FIG. D****03**

**Verrouillage**  
 Vergrendelen  
 Bloquear  
 Trancar  
 Bloccaggio  
 Locking

**FIG. E****01****b****Tirer le loquet de déverrouillage**

Trek aan de ontgrendeling  
 Tire del pestillo de liberación  
 Puxe a trava de liberação  
 Tirare il fermo di rilascio  
 Pull the release latch

**a****Appuyer sur la tête**

Druk op de kop  
 Presionar la cabeza  
 Pressione a cabeça  
 Stampa il capo  
 Press the head



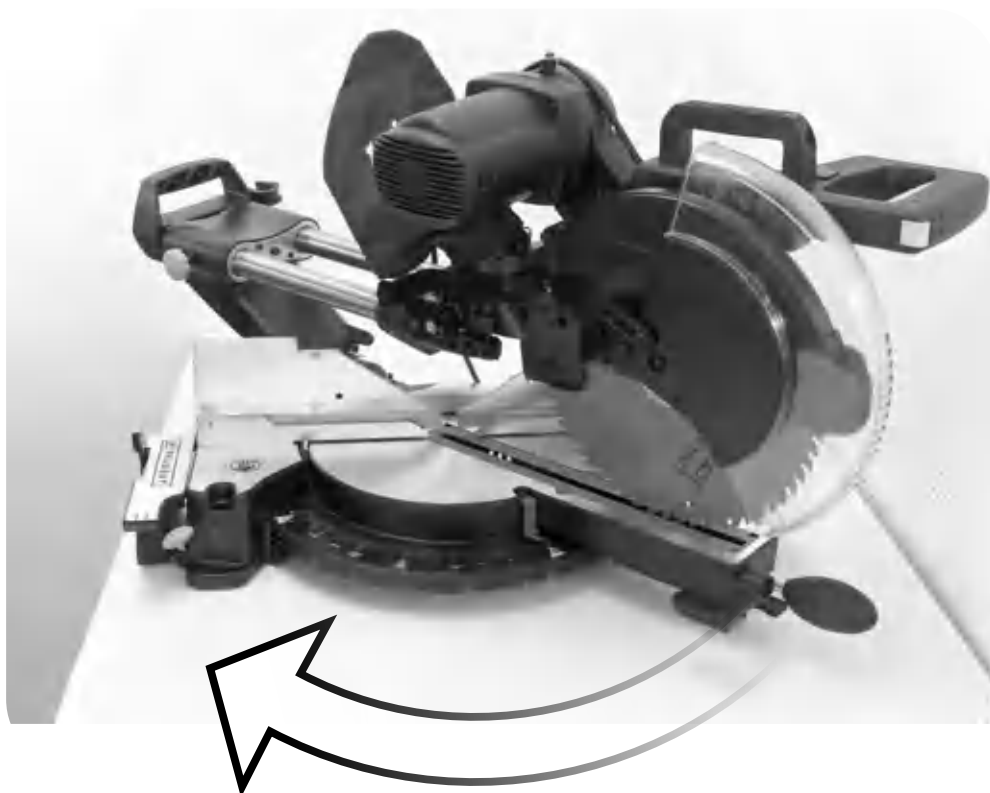
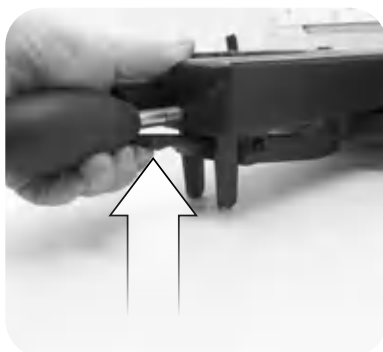
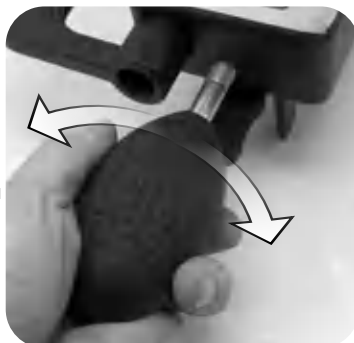

**FIG. E**

02



**Déverrouillage du plateau**  
Ladevergrendeling  
Bloqueo de bandeja  
Bandeja de bloqueio  
Blocco del vassoio  
Unlock



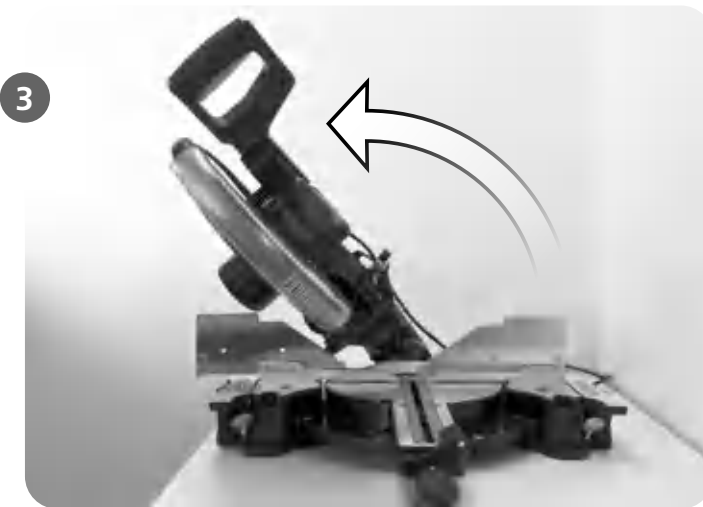
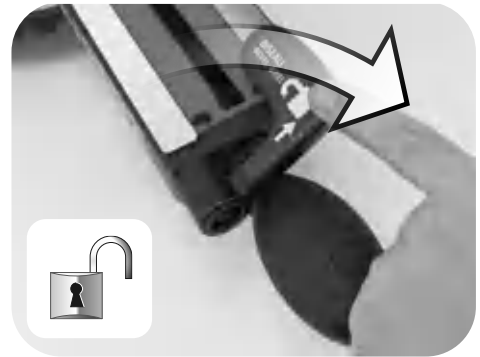



**FIG. E**

**03**

Inclinaison de la tête à gauche  
Head tilt links  
Inclinación de la cabeza hacia la izquierda  
A inclinação da cabeça para a esquerda  
Inclinare la testa a sinistra  
Head tilt left



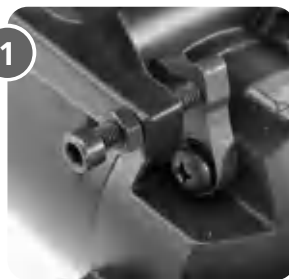

**FIG. E**

**03**

Inclinaison de la tête à droite  
Head tilt rechts  
Inclinación de la cabeza hacia derecha  
A inclinação da cabeça para a direita  
Inclinare la testa destra  
Head tilt right

**1**



**2**



**3**



**4**

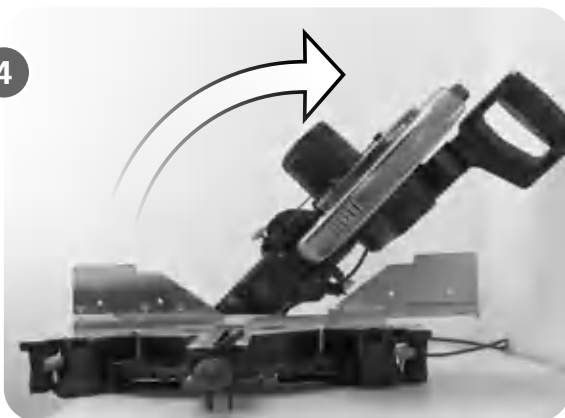



**FIG. E**

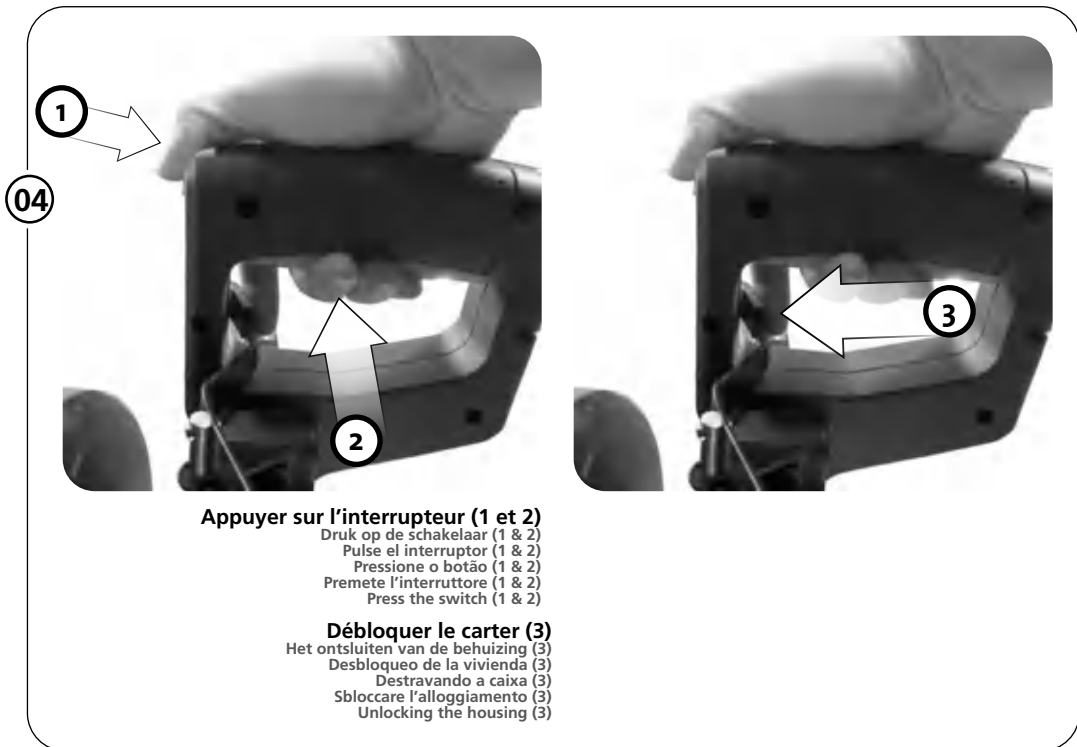

**Interrupteur pour gaucher et droitier**

Schakel links en rechtshandig  
Cambiar izquierda y la mano derecha  
Alternar esquerda e direita handed  
Interruttore di sinistra e di mano destra  
Switch left and right handed





**FIG. E**

05



**Fonction radiale : capacité de coupe accrue**

Radial functie: verhoogde snijcapaciteit  
Función Radial: mayor capacidad de corte  
Função radial: o aumento da capacidade de corte  
Funzione radiale: aumento della capacità di taglio  
Radial function: increased cutting capacity

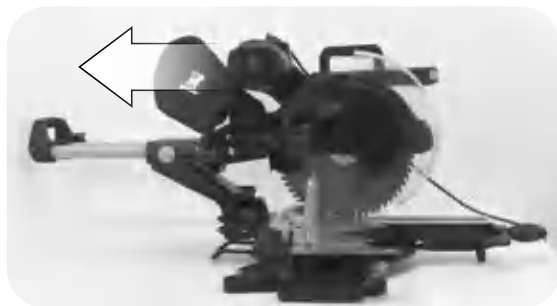

05

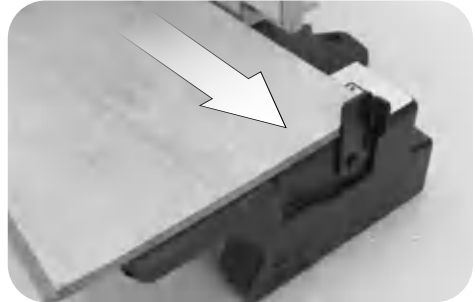
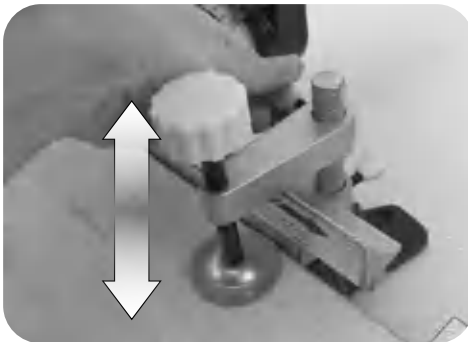

**FIG. E****07****08**

**Maintenir fermement la pièce à couper. Abaisser la tête lentement, et scier la pièce de bois à une vitesse régulière (pas d'à-coups). Attendre l'arrêt complet de la lame avant de remonter la tête de la machine lentement.**

Stevig vast te houden het werkstuk. Verlagen langzaam zijn hoofd, en zag er een stuk hout met een constant snelheid (niet een eikel). Wacht een volledige stop voordat het blad de kop machine langzaam.

Sujete firmemente la pieza de trabajo. Bajando la cabeza lentamente, y aserrar el trozo de madera a una velocidad constante (sin sacudido). Espere la parada completa antes de volver a subir la hoja de la cabeza de la máquina lentamente.

Segure firmemente a peça. Abaixando a cabeça lentamente, e viu ali pedaço de madeira a uma velocidade constante (não é um idiota). Espere uma parada completa antes que a lâmina até a cabeça da máquina lentamente.

Tenere saldamente il pezzo da lavorare. Abbassare lentamente la testa, e vide li pezzo di legno ad una velocità costante (non un coglione). Attendere il completo arresto prima che la lama la testa della macchina lentamente.

Firmly hold the workpiece. Lowering his head slowly, and saw the piece of wood at a steady speed (without jerk). Wait the complete stop of the blade before pull up the machine head slowly.





**FIG. E**

09

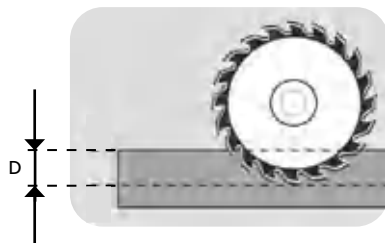
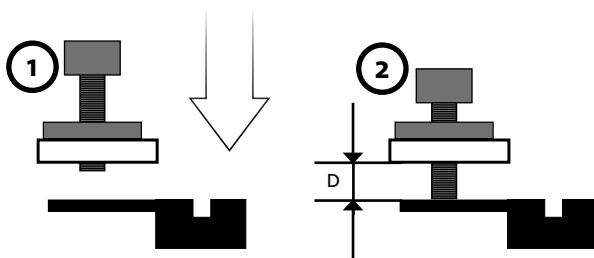

**Réglage de la butée de profondeur pour effectuer du rainage**

Aanpassen van de dieptemeter te voeren groovende  
Ajustar el calibre de profundidad para realizar el ranurado  
Ajustar o medidor de profundidade para realizar grooving  
Regolazione del misuratore di profondità per eseguire scanalature  
Adjusting the depth gauge to perform grooving





**FIG. F**

### Réglage de la butée à 90°

Aanpassing van de aanslag 90°

Ajuste de la parada de 90°

Ajustamento do batente 90°

Regolazione della battuta 90°

Adjustment of the 90° stop

**01**

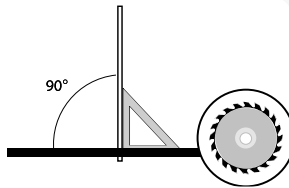

**Incorrect : réglage nécessaire**

**Onjuist: aanpassing vereist**

**Incorrecto: se requiere ajuste**

**Incorreto: ajuste necessário**

**Impossibile: la regolazione è necessaria**

**Incorrect: adjustment required**



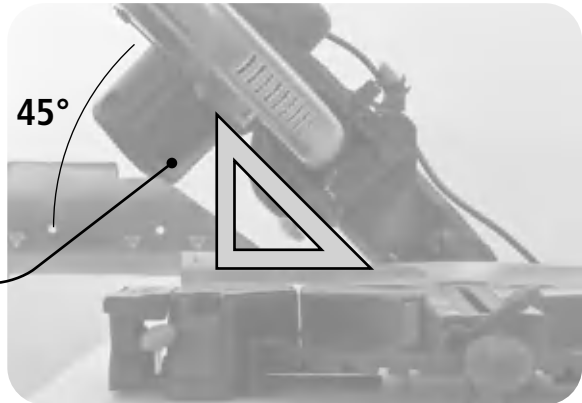
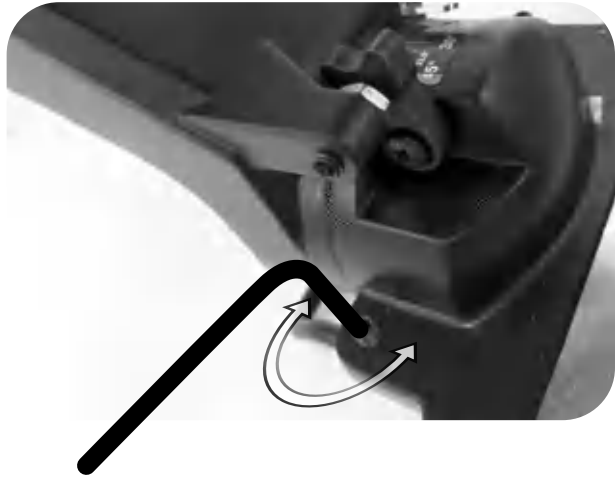
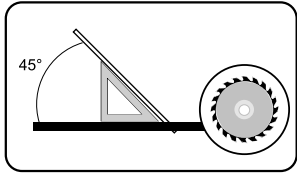

**FIG. F**

**02**

**Réglage de la butée à 45°**

Aanpassing van de aanslag 45°  
Ajuste de la parada de 45°  
Ajustamento do batente 45°  
Regolazione della battuta 45°  
Adjustment of the 45° stop



**Effectuer le réglage à l'aide d'une équerre**

Verstel met een hoekbeugel  
Ajuste con un soporte angular  
Ajuste com um suporte angular  
Regolare con una staffa ad angolo  
Adjust with an angle bracket







**Réglage de la butée à 90°**  
Aanpassing van de aanslag 90°  
Ajuste de la parada de 90°  
Ajustamento do batente 90°  
Regolazione della battuta 90°  
Adjustment of the 90° stop

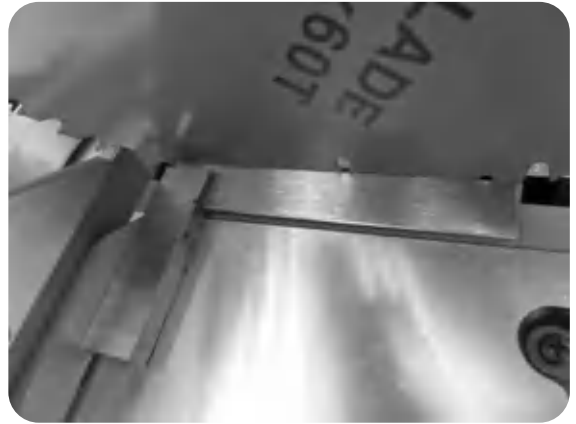



**FIG. G**

01

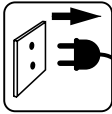

**Toujours s'assurer que la machine est débranchée du secteur avant d'effectuer toute opération.**

Zich nog steeds wordt ervan overtuigen dat het bekosttooft uitgeschakeld alvorens elke verrichting uit te voeren.  
Siempre asegurarse que la máquina sea desconectada antes efectuar cualquier operación.  
Sempre assegurar-se que a máquina é desligada antes de efectuar qualquer operação.  
Sempre assicurarsi che la macchina è staccato prima di effettuare ogni operazione.  
Please always make sure that the machine is disconnected before carrying out any operation.

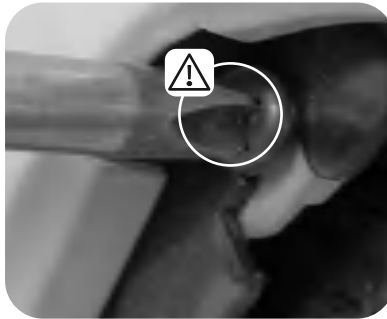

**Ne pas enlever la vis**

Draai de schroef  
Niet te verwijderen  
No retire el tornillo  
Não retire o parafuso  
Non rimuovere la vite  
Don't remove the screw

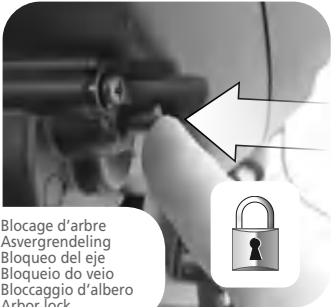
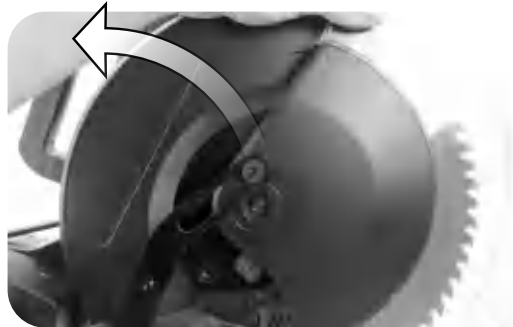

Blocage d'arbre  
Asvergrendeling  
Bloqueo del eje  
Bloqueio do veio  
Bloccaggio d'albero  
Arbor lock



**Attention : pas inversé. Dévisser dans le sens des aiguilles d'une montre**

Waarschuwing: omgekeerde schroefdraad. Schroef in de richting van de klok mee  
Advertencia: rosca invertida. Tornillo en la dirección de las agujas del reloj  
Aviso: rosca inversa. Parafuso no sentido dos ponteiros do relógio  
Attenzione: filetto inverso. Avvitare in direzione oraria  
Warning: reverse thread. Screw in the direction of clockwise





**FIG. G**

**01**



**Ref 801349 - 40 T**  
**Ref 801353 - 60 T**

**801349 :**  
Lame 40 dents pastilles de carbure  
Blade 40 tanden hardmetalen wisselplaten  
Hoja de 40 dientes de carburo de insertos  
Inserere lâmina de 40 dentes de metal duro  
40 T blade  
Lama 40 denti

**801353:**  
Lame 60 dents pastilles de carbure  
Blade 60 tanden hardmetalen wisselplaten  
Hoja de 60 dientes de carburo de insertos  
Inserere lâmina de 60 dentes de metal duro  
60 T blade  
Lama 60 denti

**02**



**Répéter l'opération pour l'autre coté**

Herhaal dit voor de andere kant  
Repita para el otro lado  
Repita a operação para o outro lado  
Ripetere l'operazione per l'altro lato  
Repeat operation for the other side

**X2**



**03**

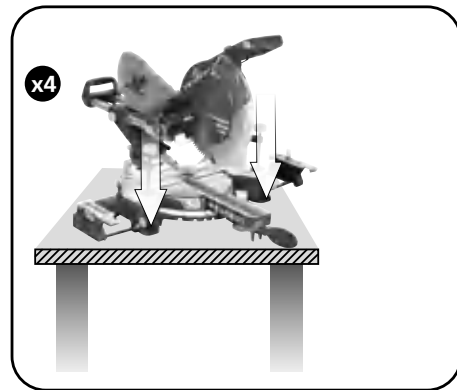



**FIG. H**

### Transport de la machine

Vervoeren Machine  
Transporte de la máquina  
Transporte da máquina  
Il trasporto della macchina  
Transportation of the Machine



### Fixation de l'ensemble

Vaststelling van de draaibank  
Fijación del torno  
Fixação do Torno  
Fissaggio del tornio  
Fixing the lathe





### **Vider le sac à poussières régulièrement et avant tout nouveau travail !**

Leeg de stofzak regelmatig en voordat een nieuw werk!

Vacía la bolsa de polvo con regularidad y antes de cualquier nuevo trabajo!

Esvazie o saco de pó regularmente e antes de qualquer novo trabalho!

Svuotare il sacchetto di polvere regolarmente e prima di ogni nuovo lavoro!

Empty the dust bag regularly and before any new work!

### **Raccordement à un aspirateur**

Aansluiten van een stofzuiger

Conexión de una aspiradora

Conexão de um aspirador de pó

Collegamento di un aspirapolvere

Connecting a vacuum cleaner

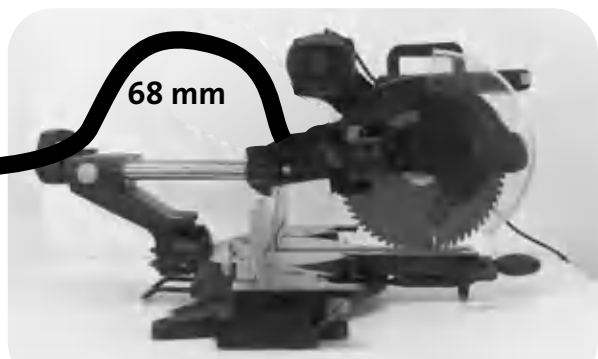

  
**FR****Description et repérage des organes de la machine****FIG. A & B**

- 01 Carter de protection
- 02 Interrupteur
- 03 Charbons
- 04 Orientation du plateau
- 05 Verrouillage du plateau
- 06 Butée de longueur
- 07 Presse de serrage
- 08 Graduation du plateau
- 09 Laser
- 10 Inclinaison de la tête
- 11 Ajustement angulaire de la butée
- 12 Fonction radiale
- 13 Extension de table

**Contenu du carton****FIG. C****Assemblage de la machine****FIG. D**

- 01 Montage du sac à poussières
- 02 Montage butée et extension
- 03 Montage presses de serrage

**Fonctionnalité de la machine****FIG. E**

- 01 Déverrouillage de la machine
- 02 Orientation du plateau
- 03 Inclinaison de la tête
- 04 Comment faire une coupe
- 05 Comment se servir de la fonction radiale
- 06 Allumage du laser et éclairage LED
- 07 Utilisation des butées
- 08 Maintenir une pièce à couper
- 09 Fonction rainurage

**Réglages de la machine****FIG. F**

- 01 Régler la coupe à 90°
- 02 Régler la coupe à 45°
- 03 Réglage du laser

**Remplacement des consommables****FIG. G**

- 01 Changement de lame
- 02 Changement des charbons

**Transport et fixation****FIG. H****Entretien, recommandations et conseils**

- 01 Ne pas utiliser les scies à onglet pour la coupe de bois de chauffage
- 02 Ne pas forcer sur la machine.
- 03 Il est préférable de relier votre machine à un aspirateur pour collecter le maximum de poussière

  
**EN****Description and location of machine parts****FIG. A & B**

- 01 Protection guard
- 02 Switch
- 03 Carbon rods
- 04 Orientation of plate
- 05 Locking of plate
- 06 Length stop
- 07 Clamp
- 08 Plate scale
- 09 Laser
- 10 Angle of head
- 11 Adjustment of stop to 45°/90° angles
- 12 Radial function
- 13 Table extensions

**Contents of box****FIG. C****Assembling the machine****FIG. D**

- 01 Mounting of dust bag
- 02 Mounting of stops and extensions
- 03 Mounting of clamping vices

**Machine Functions****FIG. E**

- 01 Unlocking of the machine
- 02 Orientation of plate
- 03 Angle of head
- 04 How to make a cut
- 05 How to use the radial function
- 06 Turning on the laser and LED light
- 07 Using the length stops
- 08 Holding a piece you are cutting
- 09 Groove function

**Machine settings****FIG. F**

- 01 Adjusting a cut to 90°
- 02 Adjusting a cut to 45°
- 03 Adjusting the Laser

**Replacement of consumables****FIG. G**

- 01 Changing the blade
- 02 Changing the carbon rods

**Fixation and transport****FIG. H****Maintenance, recommendations and advice**

- 01 Do not use mitre saws for cutting firewood
- 02 Do not push too hard on the machine.
- 03 It is better to hook your machine up to a vacuum cleaner in order to collect as much dust as possible

**Descripción y localización de los elementos****FIG. A & B**

- 01** Cártér de protección
- 02** Interruptor
- 03** Carbones
- 04** Orientación de la mesa
- 05** Bloqueo de la mesa
- 06** Tope de longitud
- 07** Cárcel
- 08** Graduación de la mesa
- 09** Láser
- 10** Inclinación de la cabeza
- 11** Ajuste angular del tope 45°/ 90°
- 12** Función radial
- 13** Extensiones de la mesa

**Contenido del cartón****FIG. C****Ensamblaje de la máquina****FIG. D**

- 01** Montaje de la bolsa para el polvo
- 02** Montaje de los topes y extensiones
- 03** Montaje de los tornillos de sujeción

**Funcionalidad de la máquina****FIG. E**

- 01** Desbloqueo de la máquina
- 02** Orientación de la mesa
- 03** Inclinación de la cabeza
- 04** Cómo realizar un corte
- 05** Cómo servirse de la función radial
- 06** Encender el láser
- 07** Utilización de los topes de longitud
- 08** Sujetar la pieza que se tiene que cortar
- 09** Hacer un surco

**Configuración de la máquina****FIG. F**

- 01** Ajuste del corte a 90°
- 02** Ajuste del corte a 45°
- 03** Ajuste del Láser

**Sustitución de consumibles****FIG. G**

- 01** Cambio de hoja
- 02** Cambio de los carbones.

**Transporte y fijación****FIG. H****Asesoramiento, recomendaciones y mantenimiento**

- 01** No utilizar las sierras de ingletes para cortar leña de calefacción
- 02** No ejercer fuerza en la máquina
- 03** Es preferible conectar su máquina a un aspirador para coleccionar la mayor cantidad posible de polvo

**Descrizione e localizzazione degli organi****FIG. A & B**

- 01** Carter di protezione
- 02** Interruttore
- 03** Carboni
- 04** Orientamento del piano
- 05** Blocco del piano
- 06** Finecorsa di lunghezza
- 07** Morsetti
- 08** Graduazione del piano
- 09** Laser
- 10** Inclinazione della testa
- 11** Regolazione angolare del finecorsa 45°/ 90°
- 12** Funzione radiale
- 13** Estensioni del tavolo

**Contenuto della scatola****FIG. C****Assemblaggio della macchina****FIG. D**

- 01** Montaggio del sacco per polvere
- 02** Montaggio dei finecorsa e delle estensioni
- 03** Montaggio dei morsetti di serraggio

**Funzionalità della macchina****FIG. E**

- 01** Sblocco della macchina
- 02** Orientamento del piano
- 03** Inclinazione della testa
- 04** Come fare un taglio
- 05** Come usare la funzione radiale
- 06** Accensione del laser
- 07** Utilizzazione dei finecorsa di lunghezza
- 08** Mantenere un pezzo da tagliare
- 09** Funzione Groove

**Impostazioni della macchina****FIG. F**

- 01** Regolazione del taglio a 90°
- 02** Regolazione del taglio a 45°
- 03** Regolazione del laser

**Sostituzione dei consumabili****FIG. G**

- 01** Cambiare la lama
- 02** Cambiare i carboni

**Trasporto e fissazione****FIG. H****Manutenzione, raccomandazioni e consigli**

- 01** Non usare la sega per tagli obliqui per tagliare la legna da ardere
- 02** Non forzare sulla macchina
- 03** Si consiglia di collegare la macchina ad un aspiratore per raccogliere il massimo della polvere

**Descrição e identificação dos órgãos****FIG. A & B**

- 01 Cárter de proteção
- 02 Interruptor
- 03 Escovas
- 04 Orientação do prato
- 05 Bloqueio do prato
- 06 Fim de curso de comprimento
- 07 Mordente
- 08 Graduação do prato
- 09 Laser
- 10 Inclinação da cabeça
- 11 Ajuste angular do fim de curso 45°/ 90°
- 12 Função radial
- 13 Extensões de mesa

**Conteúdo da caixa****FIG. C****Montagem da máquina****FIG. D**

- 01 Montagem do saco de poeira
- 02 Montagem dos fins de curso e extensões
- 03 Montagem dos tornos de aperto

**Funcionalidade da máquina****FIG. E**

- 01 Desbloqueio da máquina
- 02 Orientação do prato
- 03 Inclinação da cabeça
- 04 Como efectuar um corte
- 05 Como utilizar a função radial
- 06 Acendimento do laser
- 07 Utilização dos fins de curso de comprimento
- 08 Imobilizar uma peça a cortar
- 09 Fazer um sulco

**Ajuste da máquina****FIG. F**

- 01 Ajuste do corte a 90°
- 02 Ajuste do corte a 45°
- 03 Ajuste do laser

**Substituição de consumíveis****FIG. G**

- 01 Substituição da lâmina
- 02 Mude carvões

**Transporte e fixação****FIG. H****Limpeza e manutenção preventiva**

- 01 Não utilizar as serras angulares para o corte de lenha
- 02 Não exercer força sobre a máquina
- 03 É preferível ligar a sua máquina a um aspirador, para recolher o máximo de poeira

**Beschrijving en plaatsbepaling van de onderdelen****FIG. A & B**

- 01 Beschermmantel
- 02 Schakelaar
- 03 Koolborstels
- 04 Richting van de plaat
- 05 Vergrendeling van de plaat
- 06 Lengteaanslag
- 07 Blokkeerinrichting
- 08 Plaatgradering
- 09 Laser
- 10 Hoek van de kop
- 11 Hoekverstelling van de aanslag 45°/ 90°
- 12 Radiale functie
- 13 Tafelverlengingen

**Inhoud van het karton****FIG. C****Assemblage van de machine****FIG. D**

- 01 Montage van de stofzak
- 02 Montage van de aanslagen en verlengingen
- 03 Montage van de vastzetschroeven

**Reiniging en onderhoud****FIG. E**

- 01 Ontgrendeling van de machine
- 02 Richting van de plaat
- 03 Hoek van de kop
- 04 Hoe een versnijding te doen
- 05 Hoe de radiale functie te gebruiken
- 06 Aansteken van de laser
- 07 Gebruik van de lengteaanslagen
- 08 Een te versnijden stuk behouden
- 09 Maak een groove

**Afstelling van de machine****FIG. F**

- 01 Afstelling van het versnijden op 90°
- 02 Afstelling van het versnijden op 45°
- 03 Afstelling van de Laser

**Vervanging van de accessoires****FIG. G**

- 01 Verandering van de lamel
- 02 Verandering van de koolborstels

**Transport en fixatie****FIG. H****Reiniging en onderhoud**

- 01 De verstekzagen niet gebruiken voor het versnijden van het brandhout
- 02 De verstekzagen niet gebruiken voor het versnijden van het brandhout
- 03 Het is beter om uw machine te verbinden met een stofzuiger om stof maximaal te verzamelen





	TENSION ET FRÉQUENCE ASSIGNÉE :	<b>230 V ~ 50 Hz</b>
	AANGEWEZEN SPANNING EN FREQUENTIE:	
	TENSIÓN Y FRECUENCIA FIJADA:	
	TENSÃO E FREQUÊNCIA FIXA:	
	TENSIONE E FREQUENZA ASSEGNATA:	
NOMINAL FREQUENCY AND POWER:		

	PUISSANCE ASSIGNÉE :	<b>1600 W</b>
	NOMINAL POWER:	
	LEERLAUFDREHZAHL:	
	POTENCIA FIJADA:	
	POTENZA ASSEGNATA:	
POTÊNCIA ASSINADA:		

	VITESSE À VIDE :	<b>4200 min<sup>-1</sup></b>
	LEERLAUFDREHZAHL:	
	VELOCIDAD VACÍA:	
	VELOCIDADE NO VÁCUO:	
	VELOCITÀ A VUOTO:	
NO-LOAD SPEED:		

	DIMENSIONS LAME :	<b>ø 305 mm</b>
	BLADE SIZES:	
	PANEEL AFMETINGEN:	
	DIMENSIONES DEL PANEL:	
	DIMENSÕES DO PAINEL:	
DIMENSIONI DEL PANNELLO:		

	ALÉSAGE LAME :	<b>ø 30 mm</b>
	BORE:	
	BLADE BORING:	
	PERFORACIÓN DE LA LÁMINA:	
	FURO LÂMINA:	
FORO LAMA:		

		<b>60 T</b>
--	--	-------------

	NIVEAU DE PRESSION ACOUSTIQUE :	<b>93,5 dB (A)</b>
	NIVEAU ACOESTISCHE DRUK :	
	NÍVEL DE PRESIÓN ACÚSTICA :	
	NÍVEL DE PRESSÃO ACÚSTICA :	
	LIVELLO DI PRESSIONE ACUSTICA :	
ACOUSTIC PRESSURE LEVEL :		

	NIVEAU DE PUISSANCE ACOUSTIQUE :	<b>106,5 dB (A)</b>
	NIVEAU ACOESTISCH VERMOGEN :	
	NÍVEL DE POTENCIA ACÚSTICA :	
	NÍVEL DE POTÊNCIA ACÚSTICA:	
	LIVELLO DI POTENZA ACUSTICA:	
ACOUSTIC POWER LEVEL :		

	NIVEAU DE VIBRATION :	<b>2,091 m / s<sup>2</sup></b>
	TRILLINGSNIVEAU HAND/ARM :	
	NÍVEL DE VIBRACIÓN MANO/BRAZO :	
	NÍVEL DE VIBRAÇÃO MÃO/BRAÇO :	
	LIVELLO DI VIBRAZIONE MANO/BRACCIO :	
HAND/ARM VIBRATION LEVEL :		

	CAPACITÉS DE COUPE :	<b>90x90° = 90x340 mm</b> <b>90x45° = 90x240 mm</b> <b>G:45°x90° = 45x330 mm</b> <b>G:45°x45° = 45x230 mm</b> <b>D:45°x45° = 40x330 mm</b>
	CUTTING CAPACITIES:	
	SNIJDEN CAPACITEITEN:	
	CAPACIDADES DE CORTE:	
	CORTAR CAPACIDADES:	
	DI TAGLIO:	

#### NIVEAU SONORE D'EMISSION:

Pression acoustique LpA poste opérateur  
Incertitude

#### A VIDE

93,5 dB  
3

Puissance acoustique LWA  
Incertitude

106,5 dB  
3

VALEURS DÉTERMINÉES SUIVANT LE CODE D'ESSAI DE L'ANNEXE B DE LA NORME EN 62841 AVEC EMPLOI DES NORMES DE BASE ISO 11201 ET ISO 3744.

LES NIVEAUX DE PRESSION ACOUSTIQUE OBTENUS IN SITU DÉPENDENT:

• DES NIVEAUX RÉELS DE LA MACHINE CONSIDÉRÉES, EN PRENANT EN COMPTE LES INCERTITUDES DÉCLARÉES.

• DU LOCAL ET DE L'INSTALLATION DE LA MACHINE. PRÉFÉREZ UNE PIÈCE DONT L'ACOUSTIQUE EST PLUS FEUTRÉE. ÉVITEZ LES PIÈCES VIDE À GRANDE RÉSONNANCE. PLACEZ VOUS AUPRÈS D'UNE FENÊTRE LE CAS ÉCHÉANT.

• DES OUTILS MONTÉS, DES PIÈCES TRAVAILLÉES, DES RÉGLAGES CHOISIS,...

#### VIBRATIONS :

VALEUR TOTALE DES VIBRATIONS DÉTERMINÉES CONFORMÉMENT AU PROTOCOLE D'ESSAI DE LA NORME EN 61029-1, POUVANT ÊTRE UTILISÉE POUR COMPARER UN OUTIL À UN AUTRE ET ÉGALEMENT POUR UNE ÉVALUATION PRÉLIMINAIRE DE L'EXPOSITION.

a<sub>h</sub> INFÉRIEUR À 2,5 m/s<sup>2</sup>  
Incertitude K 1,5 m/s<sup>2</sup>

AVERTISSEMENT : L'ÉMISSION DE VIBRATION AU COURS DE L'UTILISATION RÉELLE DE L'OUTILS DE PUISSANCE PEUT DIFFÉRER DE LA VALEUR TOTALE DÉCLARÉE, SELON LES MÉTHODES D'UTILISATION DE L'OUTIL.





	LASER :	X
	LASER:	
	LASER:	
	LASER:	
	LASER:	
	LASER:	

	POIDS :	28,0 kg
	GEWICHT:	
	PESO:	
	PESO:	
	PESO:	
	WEIGHT:	

	RISQUE DE SECTIONNEMENT DES DOIGTS OU DE LA MAIN :	X
	SNIJDEN RISICO VAN DE VINGER OF HAND:	
	RECYCLEBAAR, ONDER VOORBEHOUD VAN HET SORTEREN:	
	SECCIONAMIENTO RIESGO DEL DEDO O DE LA MANO:	
	RISCO SECCIONAMENTO DO DEDO OU A MÃO:	
	SEZIONAMENTO RISCHIO DEL DITO O DELLA MANO:	

	CLASSE D'ISOLEMENT : 2	X
	ISOLATIE KLASSE: 2	
	AISLAMIENTO CLASE: 2	
	ISOLAMENTO CLASSE: 2	
	ISOLAMENTO CLASSE: 2	
	INSULATION CLASS: 2	

	PORTER UNE PROTECTION AUDITIVE :	X
	PORTER DES LUNETTES DE SÉCURITÉ :	
	PORTER UN MASQUE ANTI-POUSSIÈRE :	
	DRAAG GEHOORBESCHERMERS:	
	DRAAG EEN STOFMASKER:	
	DRAAG EEN VEILIGHEIDSBRIL:	
	UTILIZAR UMA PROTECÇÃO AUDITIVA:	
	LLEVAR PUESTA UNA CARETA DE PROTECCIÓN CONTRA EL POLVO:	
	LLEVAR PUESTAS GAFAS PROTECTORAS:	
	UTILIZAR UMA PROTECÇÃO AUDITIVA:	
	UTILIZAR UMA MÁSCARA ANTI-POEIRA:	
	UTILIZAR ÓCULOS DE SEGURANÇA:	
	PORTARE UNA PROTEZIONE UDITIVA:	
	INDOSSARE UNA MASCHERINA ANTI-POLVERE:	
PORTARE DI GLI OCCHIALI DI SICUREZZA:		
WEAR HEARING PROTECTIVE EQUIPMENT:		
WEAR A DUST MASK:		
WEAR PROTECTIVE EYEWEAR:		

	CONFORMITÉ EUROPÉENNE :	X
	VOLDOET AAN DE EG-NORMEN:	
	CUMPLE CON LAS DIRECTIVAS CE:	
	CONFORME ÀS NORMAS CE:	
	CONFORME ALLE NORME CE:	
	CONFORMS TO EC STANDARDS:	

	LIRE LES INSTRUCTIONS AVANT USAGE :	X
	LEES VOOR HET GEBRUIK DE INSTRUCTIES:	
	LÉASE LAS INSTRUCCIONES ANTES DE USAR:	
	LER AS INSTRUÇÕES ANTES DA UTILIZAÇÃO:	
	LEGGERE LE ISTRUZIONI PRIMA DELL'USO:	
	READ THE INSTRUCTIONS BEFORE USE:	

	PORTER DES GANTS :	X
	DRAAG VEILIGHEIDSHANDSCHOENEN:	
	LLEVAR GUANTES DE PROTECCIÓN:	
	UTILIZAR LUVAS DE PROTECÇÃO:	
	INDOSSARE I GUANTI DI PROTEZIONE:	
	USE RUBBER GLOVES:	

	DANGER :	X
	GEVAAR:	
	PELIGRO:	
	PERIGO:	
	PERICOLO:	
	DANGER:	





	SOU MIS À RECYCLAGE :	X
	NIET WEGWERPEN :	
	SOTTOPOSTI A RICICLAGGIO :	
	SUJEITOS À RECICLAGEM :	
	SOTTOPOSTI A RICICLAGGIO :	
SUBJECTED TO RECYCLING :		

**FR-RECYCLAGE DES DÉCHETS:**

LES OUTILS, ACCESSOIRES ET LEUR EMBALLAGES DOIVENT SUIVRE UNE VOIE DE RECYCLAGE ADAPTÉE. CONFORMÉMENT AUX DIRECTIVES EUROPÉENNE 2012/19/UE ET 2006/66/CE, LES COMPOSANTS D'UN PRODUIT DOIVENT ÊTRE SÉPARÉS, COLLECTÉS, RECYCLÉS OU ÉLIMINÉS EN CONFORMITÉ AVEC LES RÉGLEMENTATIONS ENVIRONNEMENTALES EN VIGUEUR. LES APPAREILS, BATTERIES, PILES, HUILES, EMBALLAGES DEVRONT ÊTRE DÉPOSÉS DANS LES SYSTÈMES D'ÉLIMINATION DES DÉCHETS SPÉCIAUX TELS QUE DÉCHETTERIES. RENSEIGNEZ VOUS AUPRÈS DE VOTRE COMMUNE POUR CONNAÎTRE L'ORGANISME LE PLUS PROCHE À MÊME DE RETRAITER OU DE COLLECTER CES DÉCHETS.

**NL-AFVAL RECYCLING:**

GEREEDSCHAP, ACCESSOIRES EN VERPAKKINGEN MOETEN VOLGEN EEN PAD GESCHIKT IS VOOR RECYCLING. VOLGENS DE EUROPESE RICHTLIJNEN 2012/19/UE EN 2006/66/CE, DE COMPONENTEN VAN EEN PRODUCT MOET WORDEN GESCHIEDEN, VERZAMELD, GERECYCLEERD OF VERWIJDERD IN OVEEREENSTEMMING MET DE MILIEUVOORSCHRIFTEN. APPARATEN, BATTERIËN, OILIE, MOET DE VERPAKING WORDEN GEDEPONEERD IN DE AFVALVERWERKING AFVAL, ZOALS STORTPLAATSSEN. NĒEM CONTACT OP MET UW GEMEENTE NAAR DE DICHTSTBIJZIJNDE AGENTSCHAP KUNNEN HERHALEN OF HET VERZAMELEN VAN DEZE AFVALSTOFFEN TE VINDEN.

**ES-RECICLADO DE LOS RESIDUOS:**

LAS HERRAMIENTAS, LOS ACCESORIOS Y LOS ENVASES TIENEN QUE SEGUIR LA VÍA DE RECICLAJE ADECUADA. EN VIRTUD DE LAS DIRECTIVAS EUROPEAS 2012/19/UE Y 2006/66/CE, LOS COMPONENTES DE UN PRODUCTO DEBEN SEPARARSE, RECOGERSE, RECICLARSE O ELIMINARSE DE ACUERDO CON LAS REGLAMENTACIONES MEDIOAMBIENTALES VIGENTES. LOS APARATOS, BATERÍAS, PILAS, ACEITES, ENVASES DEBERÁN LLEVARSE A LOS CENTROS DE ELIMINACIÓN DE RESIDUOS ESPECIALES TALES COMO LOS ECOPARQUES. PEDIR INFORMACIÓN AL MUNICIPIO PAR CONOCER EL CENTRO MÁS CERCAÑO APTO PARA RECICLAR O RECOGER DICHOS RESIDUOS.

**PT-RECICLAGEM DO LIXO:**

AS FERRAMENTAS, ACESSÓRIOS E SUAS EMBALAGENS DEVEM SEGUIR UM CANAL DE RECICLAGEM ADAPTADO. CONFORMEMENTE ÀS DIRETIVAS EUROPEIAS 2012/19/UE E 2006/66/CE, OS COMPONENTES DE UM PRODUTO DEVEM SER SEPARADOS, RECOLHIDOS, RECICLADOS OU ELIMINADOS DE ACORDO COM AS REGULAMENTAÇÕES AMBIENTAIS EM VIGOR. OS APARELHOS, BATERIAS, PILHAS, ÓLEOS E EMBALAGENS DEVERÃO SER DEPOSITADOS NOS SISTEMAS DE ELIMINAÇÃO DE DETRITOS ESPECIAIS, TAIS COMO UNIDADES DE TRIAGEM DE DETRITOS. INFORMAR-SE JUNTO AO SEU CONCELHO MUNICIPAL PARA CONHECER O ÓRGÃO MAIS PRÓXIMO HABILITADO A EVACUAR OU RECOLHER ESTES DETRITOS.

**IT-RICICLAGGIO DEI RL-UTI:**

GLI APPARECCHI, I LORO ACCESSORI ED IMBALLAGGI DEVONO ESSERE SOTTOPOSTI AD UN PROCESSO DI RICICLAGGIO APPROPRIATO. IN CONFORMITÀ CON LE DIRETTIVE EUROPEE 2012/19/UE E 2006/66/CE, I COMPONENTI DI UN PRODOTTO DEVONO ESSERE SEPARATI, RACCOLTI, RICICLATI O SMALTITI IN CONFORMITÀ CON LE NORMATIVE AMBIENTALI IN VIGORE. GLI APPARECCHI, LE BATTERIE, LE PILE, GLI OLI, GLI IMBALLAGGI DOVRANNO ESSERE CONFERITI NEI SISTEMI DI SMALTIMENTO DEI RL-UTI SPECIALI COME LE ISOLE ECOLOGICHE. INFORMARSI PRESSO IL PROPRIO COMUNE PER SAPERE QUAL È L'ENTE PIÙ VICINO IN GRADO DI FARE IL TRATTAMENTO O LA RACCOLTA DIFFERENZIATA DI QUESTI RL-UTI

**EN-WASTE RECYCLING:**

THE TOOLS, ACCESSORIES AND THEIR PACKAGING MUST USE AN APPROPRIATE RECYCLING CHANNEL. IN COMPLIANCE WITH EUROPEAN DIRECTIVES 2012/19/UE AND 2006/66/CE, A PRODUCT'S COMPONENTS MUST BE SEPARATED, COLLECTED, RECYCLED OR ELIMINATED IN ACCORDANCE WITH THE ENVIRONMENTAL REGULATIONS IN FORCE. THE APPLIANCE, BATTERIES, OILS AND PACKAGING MUST BE DEPOSITED IN THE SPECIAL WASTE ELIMINATION SYSTEMS SUCH AS THE WASTE COLLECTION CENTRES. ASK YOUR COMMUNE FOR INFORMATION ON THE NEAREST ORGANISATION IN A POSITION TO REPROCESS OR COLLECT THIS WASTE

	RECYCLABLE, SOUMIS AU TRI SÉLECTIF:	X
	Recyclable, subject to recycling:	
	RECYCLEBAAR, ONDER VOORBEHOUD VAN HET SORTEREN:	
	RECICLABLE, SIN PERJUICIO DE LA CLASIFICACIÓN:	
	RECICLÁVEL, SUJEITO A TRIAGEM:	
RICICLABILE, SOGGETTO A CERNITA:		





# EnergySaw-305STB2 / 132055

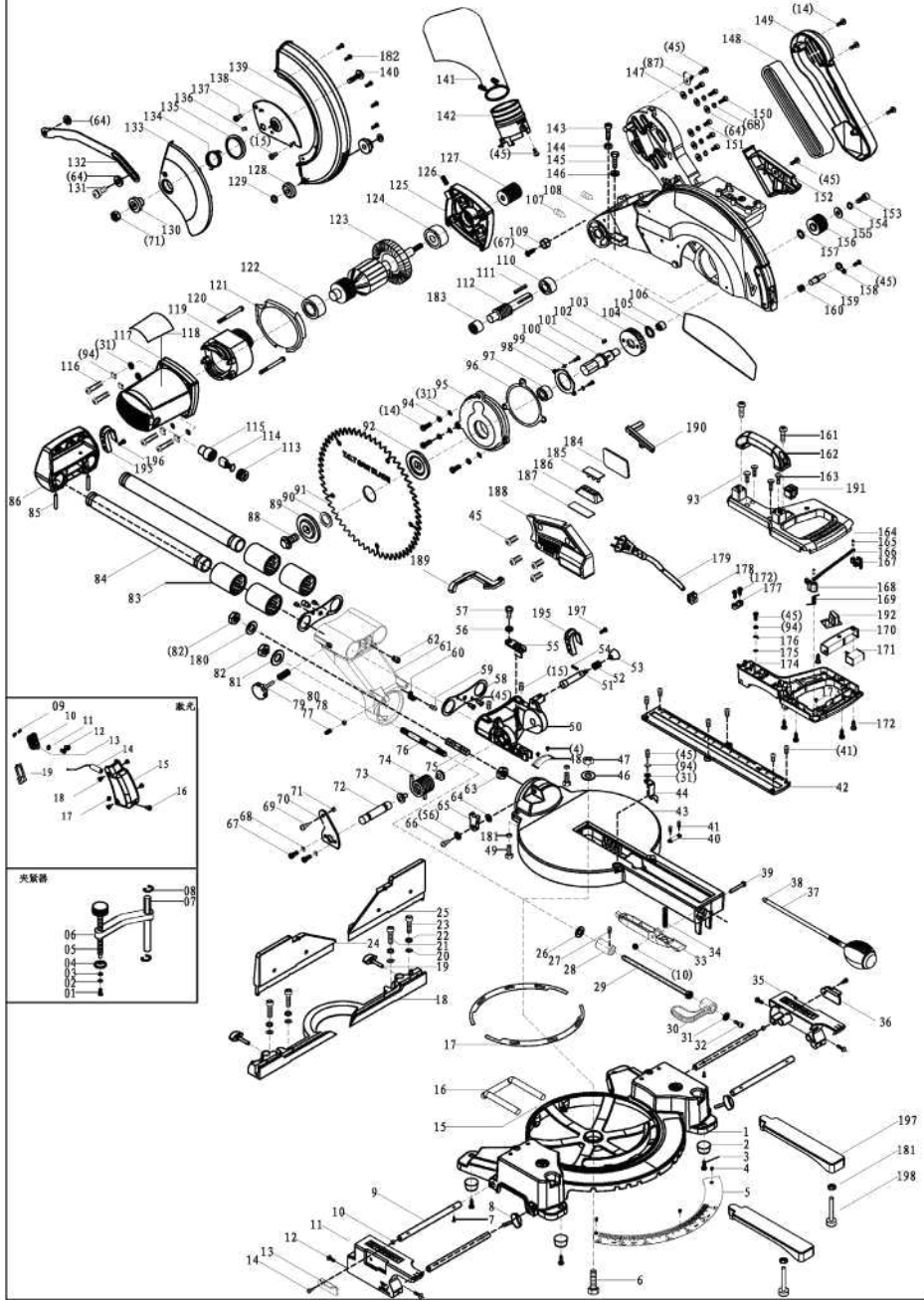



Plaques signalétiques - Naamplaatjes - Placas de identificación - Placas de identificação - Targhette - Machine labels

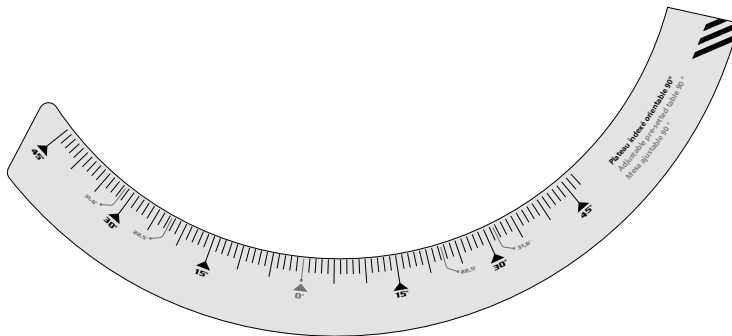
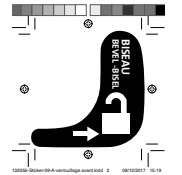
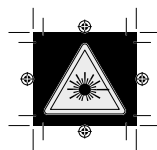
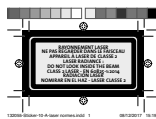
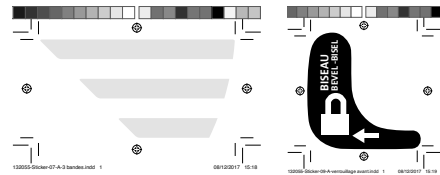
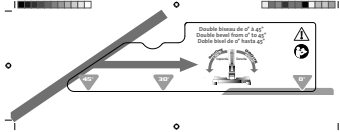
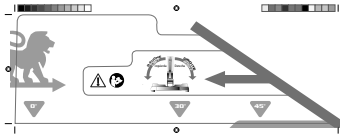
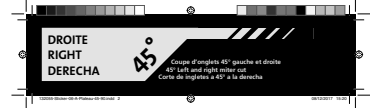
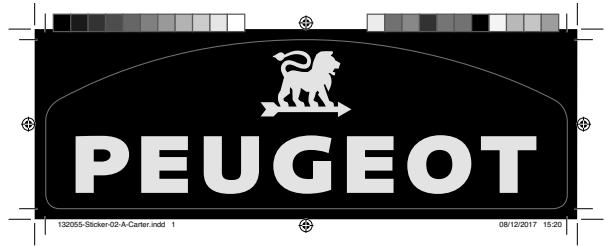



# PEUGEOT

DECLARATION CE DE CONFORMITE  
DECLARACION DE CONFORMIDAD  
DICHIARAZIONE DI CONFORMITA

VERKLARING VAN OVEREENSTEMMING  
DECLARAÇÃO DE CONFORMIDADE  
DECLARATION OF CE CONFORMITY

Le soussigné,  
Ondergetekende,  
El suscrito,  
O abaixo assinado,  
Il sottoscritto,  
The undersigned,

## PEUGEOT OUTILLAGE

192, Avenue Yves farge - 37700 St. PIERRE-des-CORPS - FRANCE  
Tél. : 02 36 16 71 46 - Fax : 02 36 16 71 40

Déclare par la présente que,  
Verklaart hiermede dat,  
Declara por la presente, que,  
Declara pela presente que,  
Dichiare che,  
Declares that,

CODE

PEUGEOT / 132055 / EnergySaw-305STB2 / 930511LF

**SCIE À ONGLETS RADIALE / SLIDING ELECTRIC MITRE SAW / SIERRA INGLETADORA RADIAL  
SERRA A ONGLETE RADIAL / TRONCATRICE RADIALE / RADIAAL VERSTEKZAAG**

Est conforme et satisfait aux normes CE:  
In overeenstemming is met en Voldoet aan EG richtlijnen:  
Cumple con la directivas de la CE:  
Respeita e está em conformidade com as normas CE:  
È conforme alle direttive CEE:  
Complies with the EEC standards:

2006/42/EC 2014/30/EU 2011/65/EU

EN62841-1:2015 EN62841-3-9:2015  
EN55014-1:2017  
EN55014-2:2015  
EN61000-3-2:2014  
EN61000-3-11:2000

Personne autorisée à  
constituer le dossier technique :  
Christophe HUREL



Christophe HUREL,  
Président Directeur Général  
24/07/2020  
Fait à Saint Pierre-des-Corps



# PEUGEOT

## BON DE GARANTIE

**1 - Objet de la garantie :**  
La garantie porte exclusivement sur les vices de fabrication ou les vices de matières.

Elle nous oblige à l'échange ou à la réparation des pièces reconnues hors d'usage.

**2 - Durée de la garantie :**

La garantie est de 24 mois à dater de la livraison du matériel à l'utilisateur (facture ou ticket de caisse à fournir).

Les échanges ou réparations faites au titre de la garantie ne peuvent avoir pour effet de prolonger celle-ci.

Les frais de port ALLER sont à la charge de l'utilisateur.

**3 - Réserves :**

La garantie ne s'applique en aucun cas aux réparations effectuées en dehors de nos réparateurs agréés.

En aucun cas, durant la période de garantie, le matériel ne devra être démonté.

## GARANTIEKAART

**1 - Doel van de garantie:**

De garantie heeft uitsluitend betrekking op fabricagefouten of gebreken in materialen.

Het dwingt ons om uit te wisselen of reparatie van erkende onbruikbare onderdelen.

**2 - Duur van de garantie:**

De garantie bedraagt 24 maanden vanaf de levering van apparatuur voor de gebruiker (factuur of kassabon te verstrekken).

De uitwisseling of reparaties onder garantie niet te verlengen.

GO verzendkosten zijn voor rekening van de gebruiker.

**3 - Reserves:**

De garantie geldt niet in alle reparaties die buiten onze goedgekeurde reparateurs.

In ieder geval gedurende de garantie, moet het materiaal worden verwijderd.

## TARJETA DE GARANTÍA

**1 - Objeto de la garantía:**

La garantía sólo se referirán a los defectos de fabricación o defectos en los materiales.

Nos obliga a cambiar o reparación de las piezas fuera de servicio reconocido.

**2 - Duración de la garantía:**

La garantía es de 24 meses a partir de la entrega de equipos para el usuario (factura o recibo que se den).

Los intercambios o reparaciones bajo garantía no tendrá que prolongarse.

GO gastos de envío correrán a cargo del usuario.

**3 - Reservas:**

La garantía no se aplica en todas las reparaciones realizadas fuera de nuestros talleres de reparación autorizados.

En cualquier caso, durante el período de garantía, el material debe ser removido.

## CARTÃO DE GARANTIA

**1 - Finalidade da garantia:**

A garantia só relacionar com defeitos de fabricação ou defeitos em materiais.

Ela nos obriga a troca ou reparo de peças inservíveis reconhecidos.

**2 - Duração da Garantia:**

A garantia é de 24 meses a partir da entrega de equipamentos para o usuário (factura ou recibo a ser fornecido).

Trocas ou reparos sob a garantia não terá que prorrogá-la.

GO porte serão custeadas pelo usuário.

**3 - Reservas:**

A garantia não se aplica a quaisquer reparos feitos fora das nossas oficinas aprovadas.

Em qualquer caso, durante o período de garantia, o material deve ser removido.

## GARANZIA

**1 - Oggetto della garanzia:**

La garanzia si riferisce esclusivamente alla difetti di fabbricazione o difetti nei materiali.

Ci costringe a scambio o la riparazione di parti inutilizzabili riconosciuti.

**2 - Durata della garanzia:**

La garanzia è di 24 mesi dalla consegna delle attrezzature per l'utente (fattura o ricevuta da fornire).

Scambi o riparazioni in garanzia non sarà necessario prolungarla.

GO spese di spedizione sono a carico dell'utente.

**3 - Riserve:**

La garanzia non si applica in tutte le riparazioni effettuate al di fuori dei nostri riparatori autorizzati.

In ogni caso, durante il periodo di garanzia, il materiale deve essere rimosso.

## WARRANTY

**1 - Scope of the warranty :**

The warranty shall only apply to manufacturing defects or material defects.

We are obliged to exchange or repair parts that are identified as being unusable

**2 - Lifetime warranty :**

The warranty shall be valid for 24 months from the delivery date of the equipment to the user (invoice or till receipt must be provided).

Exchanges or repairs carried out under the warranty shall not extend the original warranty period.

The user shall be responsible for original shipping charges.

**3 - Reservations :**

The warranty shall not under any circumstances cover repairs carried out by a non-authorized repairer.

The equipment should not be dismantled under any circumstances during the warranty period.

DATE D'ACHAT	RÉFÉRENCE MACHINE	CACHET DU DISTRIBUTEUR
DATUM VAN AANKOOP	MACHINE VERWIJZING	DEALER STEMPEL
FECHA DE COMPRA	REFERENCIA DE MÁQUINA	COMERCIANTE DE SELLOS
DATA DA COMPRA	REFERÊNCIA DA MÁQUINA	SELO REVENDEDOR
DATA DI ACQUISTO	RIFERIMENTO MACCHINA	TIMBRO DEL RIVENDITORE
PURCHASE DATE	MACHINE CODE	DISTRIBUTOR'S STAMP

## SERVICE APRÈS VENTE - AFTER SALE SERVICE

PEUGEOT OUTILLAGE - 192, Avenue Yves Farge - 37700 St. PIERRE-des-CORPS - FRANCE -

Tél. : 02 36 16 71 44 - Fax : 02 36 16 71 40